

ASSEMBLY AND OPERATING MANUAL

LTW MANHOLE BOX VB 60

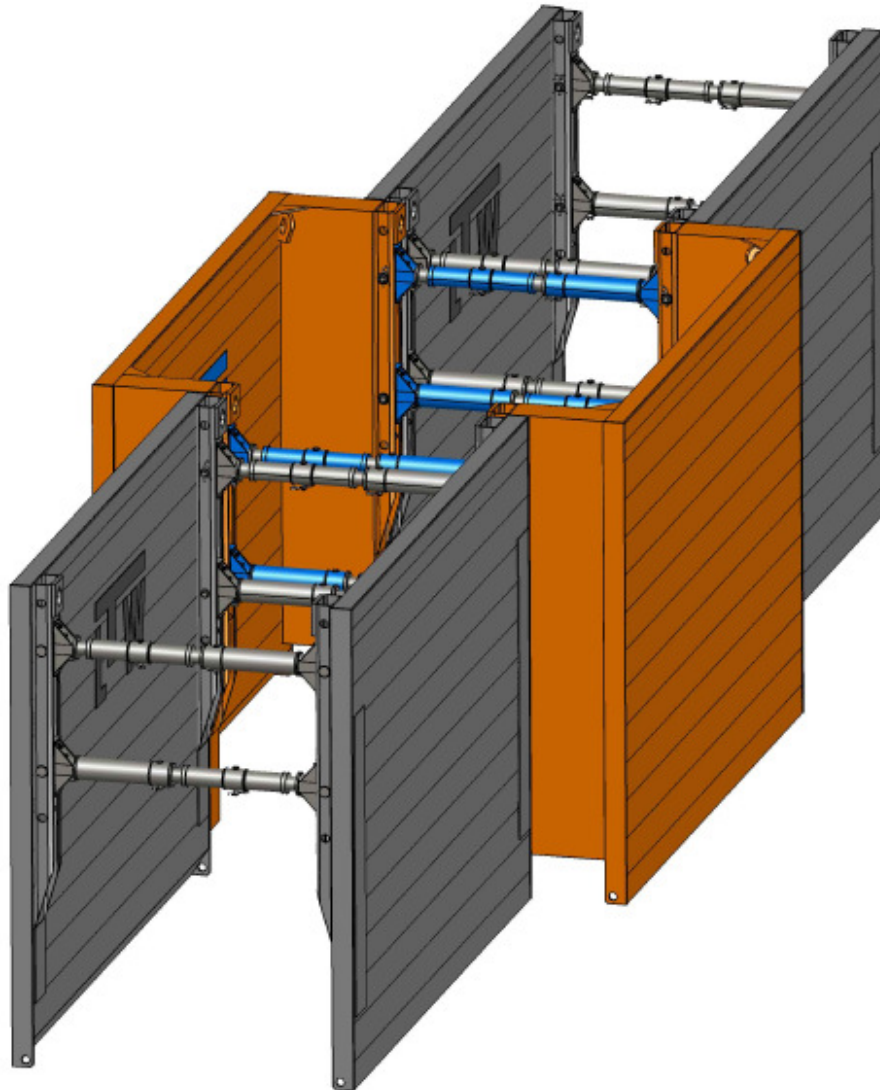

Manufacturer: **LTW Tiefbauvertriebs GmbH**
Holter Weg 11
D – 41836 Hückelhoven-Brachelen

Phone: +49 (0) 24 62 / 2009 0
Fax: +49 (0) 24 62 / 2009 15
e-mail: info@LTW-Verbau.de
homepage: [http:// www.LTW-Shoring.com](http://www.LTW-Shoring.com)



General Instructions

The LTW VB 60 Manhole Boxes can be used up to a depth of ~4,00m in the lowering and cut method with a maximum of **1 no. top Box**.

The following regulations and rules have to be followed in their valid version:

- Regulations of the BG-Fachausschuss Tiefbau (technical committee civil and underground engineering)
- DIN 4124 Baugruben und Gräben (excavation pits and trenches)
- DIN EN 13331 Teil 1 & 2 Grabenverbaugeräte (part 1 and 2 construction equipment)
- Regeln für Sicherheit und Gesundheit bei der Arbeit (rules for safety and health during work)
- Unfallverhütungsvorschriften / Arbeitsschutzvorschriften (regulations for the prevention of accidents and safety at work rules)

Our shoring components have the GS-Sign „Certified Safety“.

Please follow the instructions making use of our Boxes.

Lifting & Transportation

The shoring may only be attached at the corresponding eyes and openings and/or lifting accessories.

Lifting chains must be chosen to suit the weight being handled.

To prevent the accidental detachment of the load use only load hooks with safety catches.

The allowed tensile forces have to be kept in any cases.

Transportation has to be carried out next to soil and unneeded oscillations have to be avoided.

It is prohibited to stand within the pivoting range of the excavator or crane and beneath suspended loads.

When handling and removing the shoring, watch out for overhead contact lines (power cables).

A load operator must stand to the front of the excavator and be in eye contact with the machine operator.

Measures to reduce hazards

The safety of persons on site must be enhanced with the aid of signs, cones, warning tapes and/or safety staff specially deployed on site for this purpose.

Neighbouring traffic flow has to be made possible by means of safety staff if needed.

Personnel must wear protective clothing (helmet/safety shoes/gloves).

The risk of instability as a consequence of wind loads when setting up or using the shoring must be considered.

The shoring must be lowered onto level and firm ground. Where the ground is sloping or uneven, the shoring should be set up, if possible, at right angles to the slope.

Maintenance & Repair

Before use, all shoring components must be checked for their correct function.

Faulty or deformed parts must be replaced in any case.

Minor repairs can be carried out by the user, after consultation with LTW.

There is no warranty on incorrectly performed repairs and the use of non-original parts.

According to intenseness of use, the components should be painted with anticorrosion paint every two years.

System view

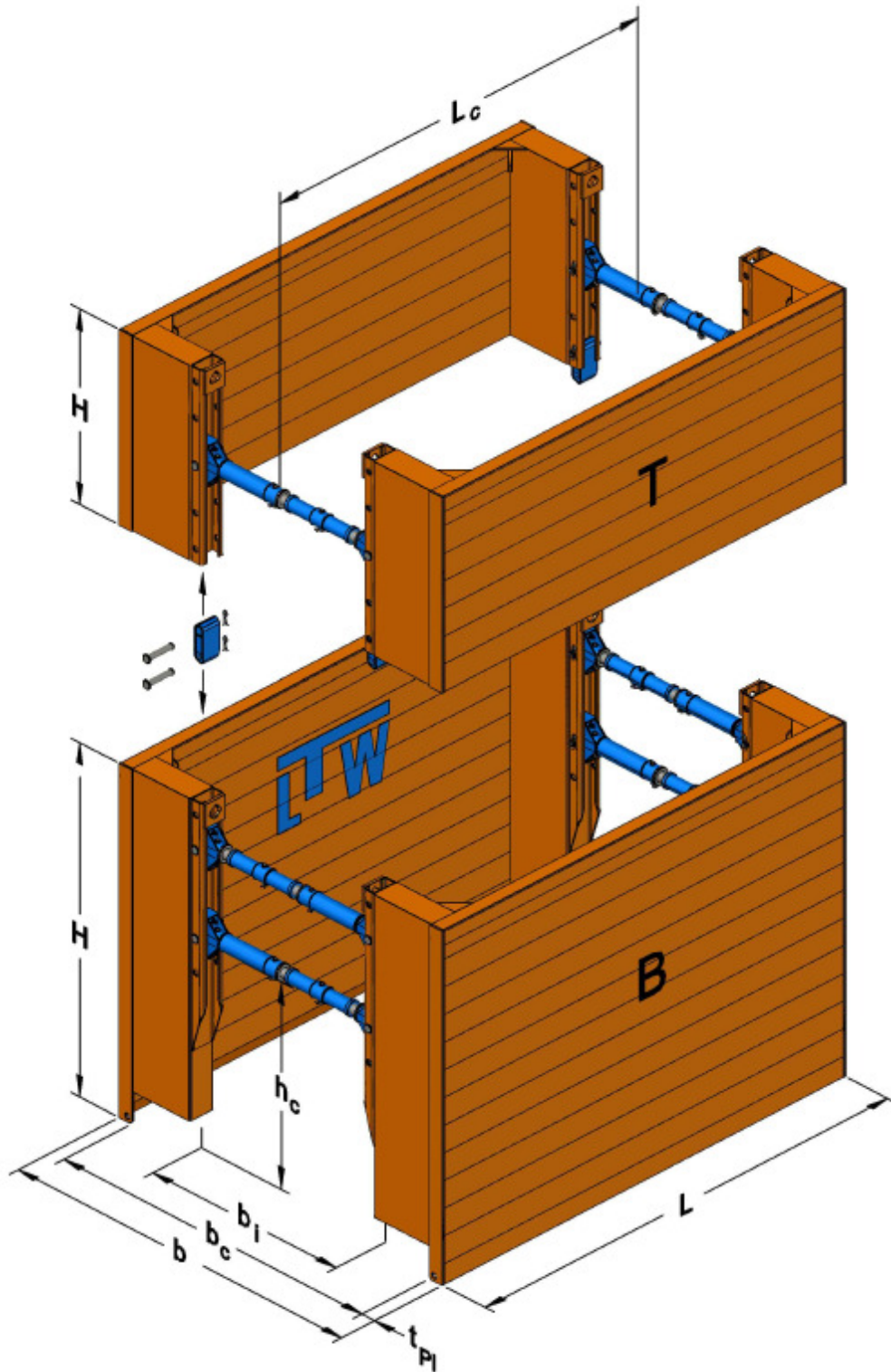

B Base Box
T Top Box
H Plate Height

b Shoring Width
b_c Inner Working Width
t_{Pl} Plate Thickness

h_c Pipe Culvert Height
L Plate Length
L_c Pipe Culvert Length

ASSEMBLY AND OPERATING MANUAL

LTW MANHOLE BOX VB 60



Technical Characteristics

Base Boxes $t_{pl} = 60 \text{ mm}$

Plate length L [m]	Plate height H [m]	Pipe culvert length L_c [m]	Pipe culvert height h_c [m]	Limit state design load e_d [kN / m ²]	Plate weight G_{PL} [kg]	Box weight G_E [kg]
2,00	2,40	1,58	1,35	66,2	525	1330
2,50	2,40	2,08	1,35	49,8	585	1450
3,00	2,40	2,58	1,35	33,0	645	1580
3,50	2,40	3,08	1,35	32,9	820	1920

Top Boxes $t_{pl} = 60 \text{ mm}$

Plate length L [m]	Plate height H [m]	Pipe culvert length L_c [m]	Pipe culvert height h_c [m]	Limit state design load e_d [kN / m ²]	Plate weight G_{PL} [kg]	Box weight G_E [kg]
2,00	1,32 1,56	1,58		66,2	340 390	820 920
2,50	1,32 1,56	2,08		49,8	375 430	890 1000
3,00	1,32 1,56	2,58		33,0	410 470	960 1080
3,50	1,32 1,56	3,08		32,9	510 585	1160 1320

Tensile Forces

lifting eyes at the plate head $R_d = 229 \text{ kN}$
 bottom eyes $R_d = 47 \text{ kN}$

Standard Strut

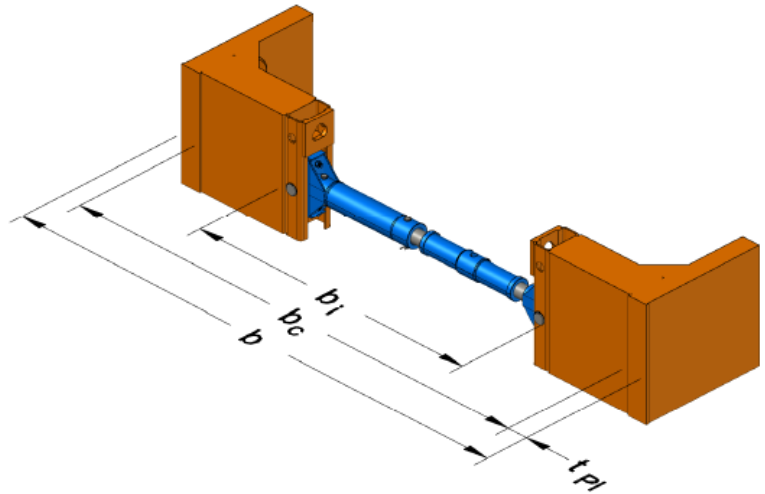

Brace Extension [m]	Working Width between C-Profiles b_i [m]	Working Width between plates b_c [m]	Shoring Width b [m]	Weight G [kg]
<i>without</i>	0,99 - 1,29	1,79 - 2,09	1,91 - 2,21	71,0
0,30	1,29 - 1,59	2,09 - 2,39	2,21 - 2,51	15,5
0,50	1,49 - 1,79	2,29 - 2,59	2,41 - 2,71	20,0
0,80	1,79 - 2,09	2,59 - 2,89	2,71 - 3,01	26,7
1,00	1,99 - 2,29	2,79 - 3,09	2,91 - 3,21	31,1
1,50	2,49 - 2,79	3,29 - 3,59	3,41 - 3,71	42,3
2,00	2,99 - 3,29	3,79 - 4,09	3,91 - 4,21	53,4
2,50	3,49 - 3,79	4,29 - 4,59	4,41 - 4,71	64,5

A strut unit consists of two spring mushrooms, the strut and, if required, a brace extension.

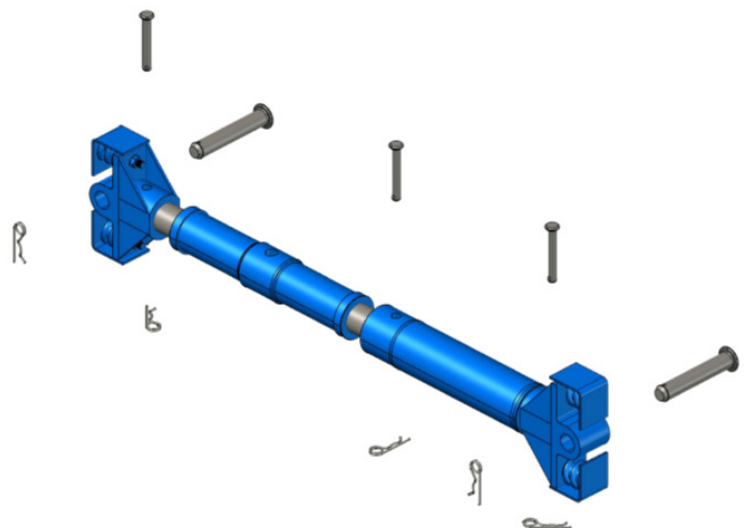

Assembly Instruction

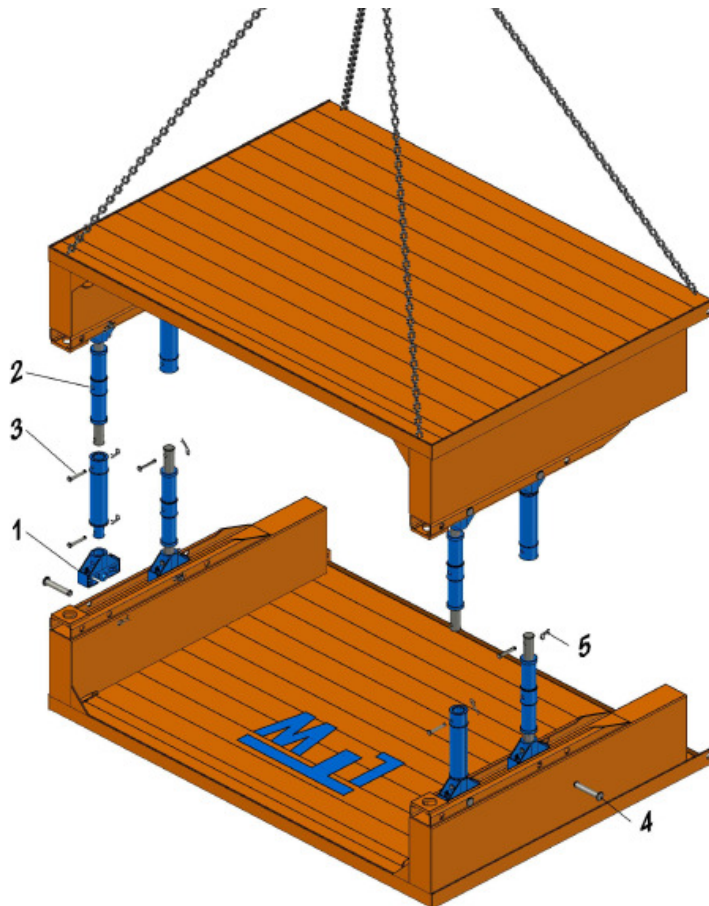

- | | | | | | |
|---|---------------|---|----------------------------------|---|--------------|
| 1 | Spring Holder | 3 | Bolt $\varnothing 20 \times 148$ | 5 | Locking Clip |
| 2 | Strut | 4 | Bolt $\varnothing 40 \times 226$ | | |

Place the Base Plate on the attachment points facing upwards.

Place 4 spring spindle holders (mushrooms) in their allocated places and secure with bolts $\varnothing 40 \times 226$ mm and locking clips. **Release the nuts to expand the spring holder.**

Put the struts and extension pipes, respectively staggered, into the spring spindle holders (shoring width up to 2.0m at one plate - greater width at two plates) and secure with bolt $\varnothing 20 \times 148$ mm and locking clips.

Per strut unit brace extensions up to a maximum lengths of 3,0m can be used.

After mounting all struts, one plate is connected to the corresponding lifting/transportation points at the top and the cutting edge. Lift the second plate above the first plate. Position carefully so that the spring spindle holder align with the struts assemblies. Carefully and slowly lower into place. Secure it with bolts $\varnothing 20 \times 148$ mm and locking clips.

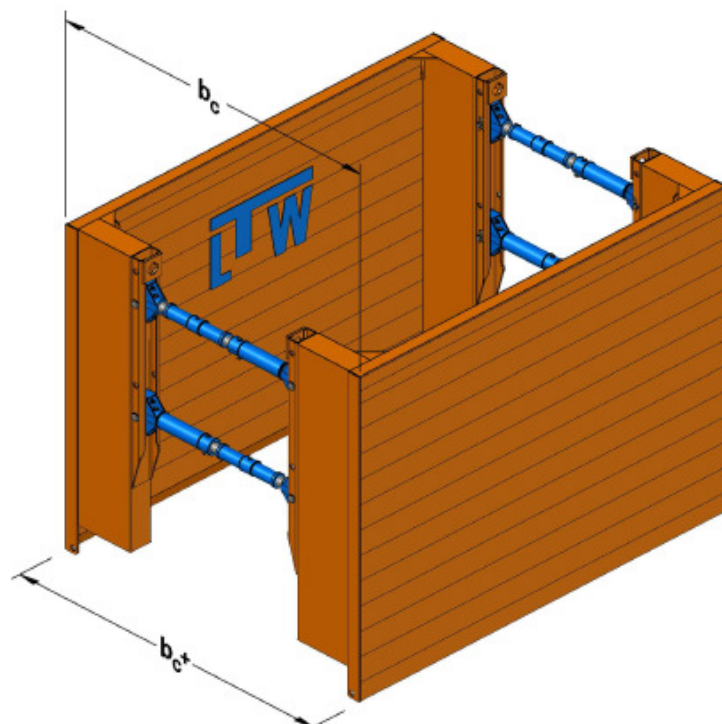

Adjust the struts to the desired trench width (fine adjustment).

Take care, to ensure that the two lower struts are adjusted 4-5cm wider than the top two. You must achieve an "A" Position. This will ensure correct alignment of the assembly as it is dug into the trench.

The assembly of the top boxes is effected as described for the base box, whereas only one strut will be adopted centred each end.

Installation Instruction

The shoring must be without gap and close to the ground. The limiting values for the max. loads have to be kept strictly. Single shoring boxes may only be used if the front and rear faces are properly secured.

Place in position method

The shoring box is placed into the totally pre-excavated trench.

The place in position method is only allowed if the following conditions are given:

- temporary steady soil
- outside of the sphere of influence of buildings and structures
- outside of the sphere of influence of circulation spaces and endangered lines
- Settlements can be accepted

The ground is considered as temporary firm, if no mayor collapses is noted in the period from the start of the excavation until the insertion of the shoring.

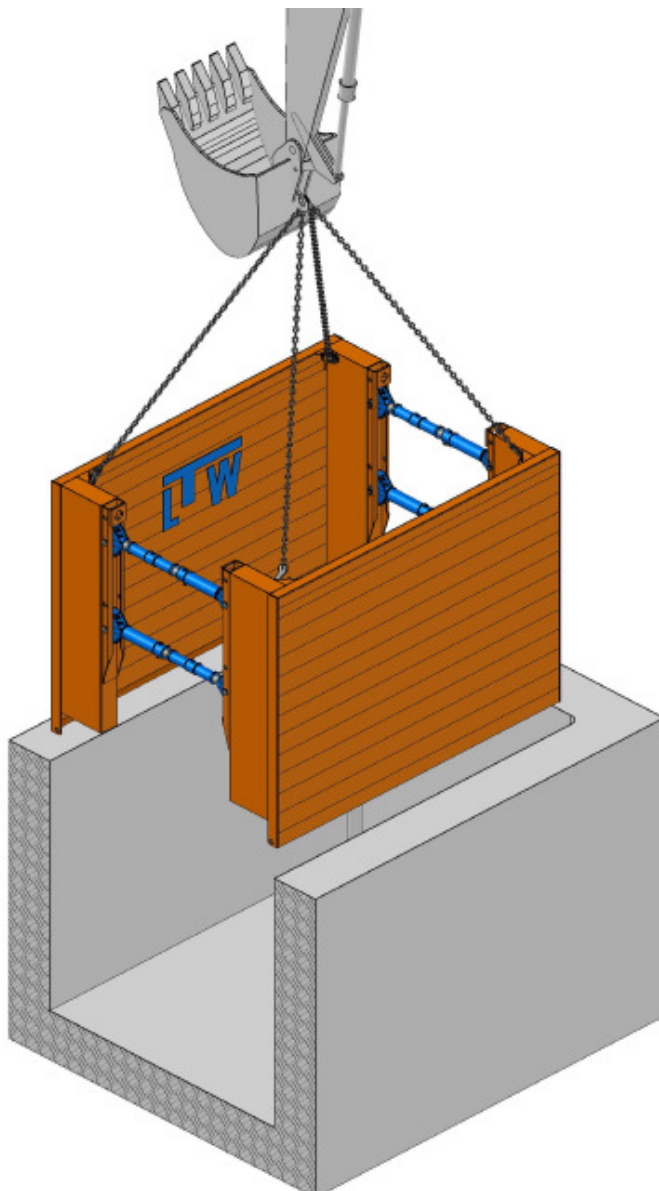

If the trench depths is greater than the Base Plate height, Base and Top modules must be assembled outside the trench and then inserted as a single unit into the trench.

Base and Top Boxes are connected with the aid of Box Connectors and bolts and must be secured by locking pins.

Connect the lifting hooks into all four lifting eyes on the top edges of the plates.

Place the completely assembled Base and Top Box as a whole into the entirely pre-excavated trench by means of lifting tools and appropriate lifting accessories. Observe the details regarding Box weights as per our technical data sheet..

The lengths of the excavated and unsecured section should not be more than the lengths of the Box.

The gap between the trench walls and the inserted shoring unit must be backfilled and compacted.

The lowering and cut method (“dig and push”)

If the soil is unsteady, the shoring box has to be pressed vertically into the ground, by alternately pushing and lowering.

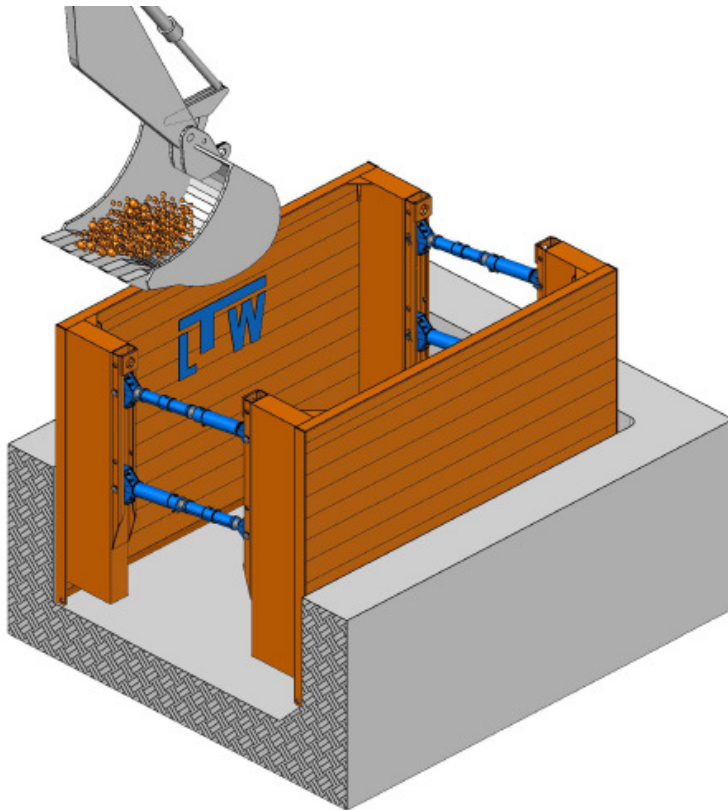

In order to protect the shoring plates we recommend using plate protectors.

Installation of Base Boxes

Pre-Excavation max. 1,25m and not more than the lengths of one Box. In principle the pre-excavation complies with the type of soil and the safety regulations.

Connect the lifting hooks into all four lifting eyes of the plates and place the adjusted base box in the pre-excavated trench, align and push it. Observe the details regarding Box weights as per our technical data sheet.

Fill the gap between the trench walls and the inserted shoring unit and compact it.

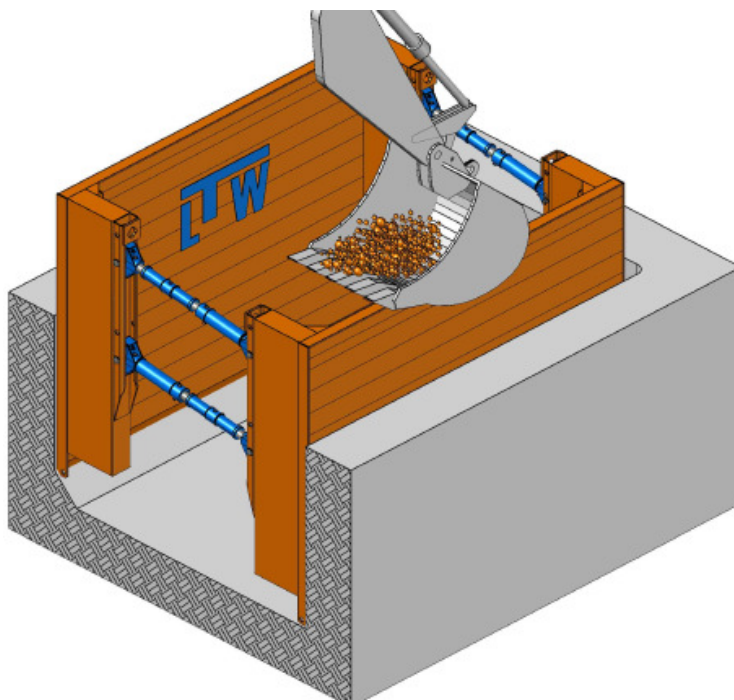

The shoring plates are to be pressed and not to be „hammered“. For safety reasons it is not allowed to push or press on the struts and brace extensions.

No personnel should enter the trench until the shoring system is fully installed to depth required.

Excavate about further 0,5m and alternately press in the plates.

As smaller the steps are carried out as better for the shoring !.

Do not press more than 0,5m on one side. The spindle assemblies have a maximum of +/-8° vertical movement available.

Continue this process until the trench has reached the desired depth.

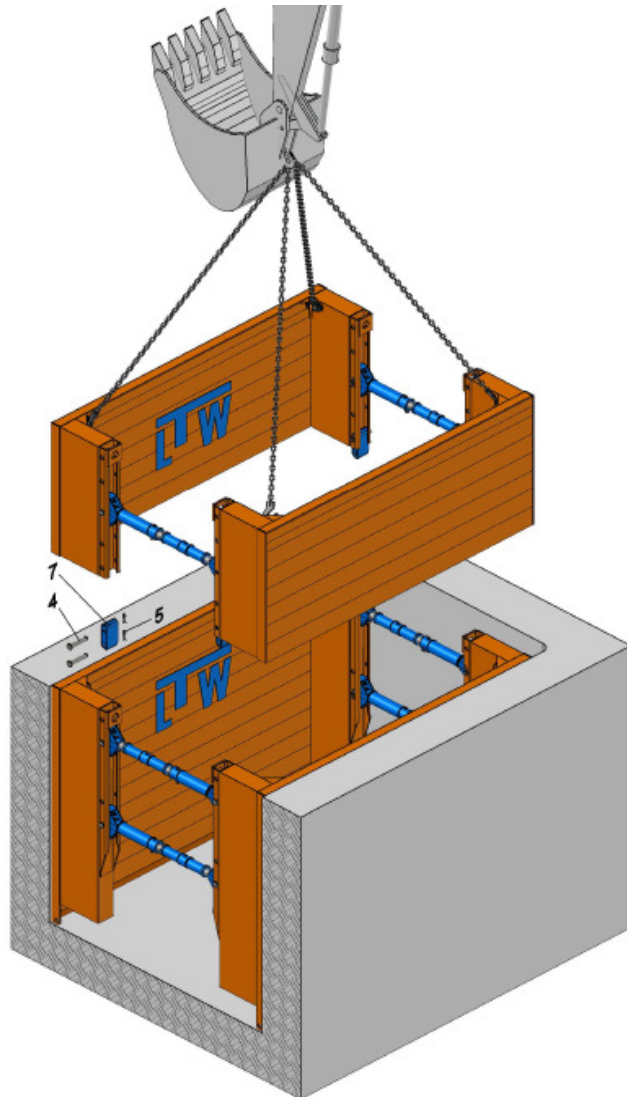

- 4 Bolt $\varnothing 40 \times 226$ 7 Box Connector
 5 Locking Clip

Installation of Top Boxes

Depending of trench depth, Top Boxes are required. Connect the lifting hooks into all four lifting eyes on the top edges of the completely assembled Top Box.

Align the Top Box over the Base Box and connect by means of Box Connectors, bolts $\varnothing 40 \times 226$ mm and locking clips.

The further installation is effected as above by alternately excavating and pressing in of the shoring plates.

The top edge of the shoring must overlap the surrounding site by at least 5cm!

Installation of the next shoring unit

Once the foregoing shoring section has been installed to full depth, it can be started with the next shoring unit....

Assemble and install the second assembly as the first.

While the shoring is place utilise the safely protected work space to lay pipe or undertake other works.

Re-Installation

After completion of the Pipe laying the re-installation of the shoring can be effected.

According to compacting possibilities bring in 0,5m filling material. Using 4 point lifting chain and lift the box by the filled height.

As smaller the lifting steps as better for the shoring! Do not lift more than 0,5m to one side and not exceed the $\pm 8^\circ$ limitation on horizontal movement of the spindle assemblies.

Repeat the procedure as described until the shoring can be lifted out of the trench according to the safety regulations.

Only use the corresponding lifting eyes for lifting! It is not allowed to lift at the struts or brace extensions!
 It is prohibited to stand within the pivoting range of the excavator or crane and beneath suspended loads.

In order to avoid an overstraining of the shoring plates, do not lift one-sided. Attach the lifting accessories at least at 2 lifting eyes of the particular plate.